

**Brightlink 70 meter / 228ft HDBaseT / HDMI 2.0 Extender / 1x2 Splitter Set over Cat6 with HDR, 4K@60Hz 4:4:4**

**MODEL: BL-EXT70-HD20-HDBT**

**Operating Instructions**



**BRIGHTLINKAV.COM**



Thank you for purchasing this product. For optimum performance and safety, please read these instructions carefully before connecting, operating or adjusting this product. Please keep this manual for future reference.

## **SAFETY PRECAUTIONS**

Please read all instructions before attempting to unpack, install or operate this equipment and before connecting the power supply.

Please keep the following in mind as you unpack and install this equipment:

- Always follow basic safety precautions to reduce the risk of fire, electrical shock and injury to persons.
- To prevent fire or shock hazard, do not expose the unit to rain, moisture or install this product near water.
- Never spill liquid of any kind on or into this product.
- Never push an object of any kind into this product through any openings or empty slots in the unit, as you may damage parts inside the unit.
- Do not attach the power supply cabling to building surfaces.
- Use only the supplied power supply unit (PSU). Do not use the PSU if it is damaged.
- Do not allow anything to rest on the power cabling or allow any weight to be placed upon it or any person walk on it.
- To protect the unit from overheating, do not block any vents or openings in the unit housing that provide ventilation and allow for sufficient space for air to circulate around the unit.

# CONTENTS

<b>1.INTRODUCTION.....</b>	<b>4</b>
<b>2.APPLICATIONS.....</b>	<b>4</b>
<b>3. PACKAGE CONTENTS.....</b>	<b>4</b>
<b>4. SYSTEM REQUIREMENTS.....</b>	<b>4</b>
<b>5. FEATURES.....</b>	<b>5</b>
<b>6. SPECIFICATIONS.....</b>	<b>5</b>
<b>7. OPERATION CONTROLS AND FUNCTIONS.....</b>	<b>6</b>
<b>7.1 Transmitter Front and Rear.....</b>	<b>6</b>
<b>7.2 Receiver Front and Rear Panels.....</b>	<b>7</b>
<b>8. CONNECTION DIAGRAM.....</b>	<b>8</b>
<b>9. MAINTENANCE.....</b>	<b>9</b>
<b>10. PRODUCT SERVICE.....</b>	<b>9</b>
<b>11. WARRANTY.....</b>	<b>9</b>

## **1. INTRODUCTION**

This Model allows HDMI signals to be transmitted over a Single CAT5e/6 cable. This solution has the added features of RS232 and 2-way IR control functionality over the same CAT5e/6 cable. It can extend 4K@60Hz HDR 10 over a HDBaseT link and upto 40M ! The slimmest HDBaseT design, making it perfect to mount behind ultra thin TVs.

## **2. APPLICATIONS**

- Household entertainment sharing and control
- Lecture room display and control
- Showroom display and control
- Meeting room presentation and control
- Classroom display and control

## **3. PACKAGE CONTENTS**

- ① Main unit
- ② Operating instructions
- ③ 24V1A DC power supply
- ④ 1xIR TX unit
- ⑤ 1xIR RX unit
- ⑥ 2 Phoenix plugs for RS232 cable termination

## **4. SYSTEM REQUIREMENTS**

Input HDMI source equipment such as DVD/Blu-ray player and HDMI equipped output display (TV or monitor).

## 5. Features

- Bandwidth up to 18Gbps, resolution up to 4k @60hz YUV 4:4:4
- Transmit up to 70m under 1080p, 40m under 4k
- Support HDR10, 3D
- With 1x looping HDMI out at Transmitter and 2 x HDMI out at Receiver
- Bi-directional wide band IR and RS232 Pass through
- Dual POC (Receiver powered by transmitter or transmitter powered by Receiver)
- HDCP2.2/ HDCP1.4 Compliant

## 6. Specifications

Operating Temperature Range	-10 to +55°C (14 to +131 °F)
Operating Humidity Range	5 to 90 % RH (no condensation)
Input Video Signal	0.5-1.0 volts p-p
Input DDC Signal	5 volts p-p (TTL)
Video Format Supported	DTV/HDTV; 4K/1080P/1080i/720P(50HZ)/576P/480P/576i/480i
Output Video	HDMI 2.0+HDCP1.4/2.2
Output Audio	Support DTS-HD, Dolby-HD
Maximum Transmission Distance	70 meters for 1080P, 40 meters for 4K
Power Supply	24V1A
Poc	Power from TX to RX over Cat5/6 cable
Power Consumption	12Watts
Dimensions	139.4mmH×66.8mmW×20mmD
Mass (Main unit)	0.7Kg / 1.54lb (Pairs)

## 7. OPERATION CONTROLS AND FUNCTIONS

### 7.1 Transmitter Front and Rear

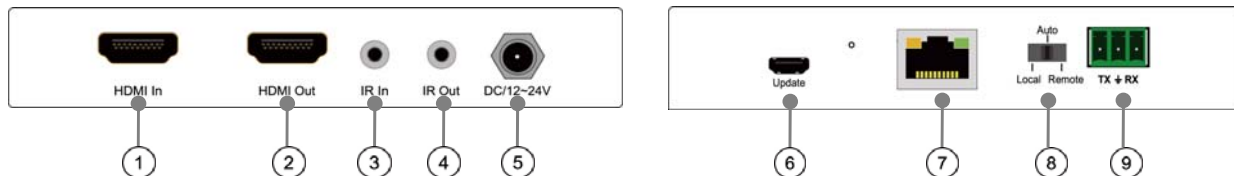

- ① HDMI In: Connect to HDMI source equipment such as DVD or Blu-ray player
- ② HDMI Out: Connect to a HDMI equipped TV/Monitor for display of the HDMI input source signal
- ③ IR In: Connect to the supplied IR blaster cable for IR signal transmission. Place the IR blaster in direct line-of-sight of the equipment to be controlled.
- ④ IR Out: Connect to the supplied IR blaster cable for IR signal transmission. Place the IR blaster in direct line of sight of the equipment to be controlled
- ⑤ DC/12-24V: Plug the 24V DC power supply into the unit and connect the adaptor to an AC outlet
- ⑥ Update: USB port to update the firmware
- ⑦ CAT5e/6 Out: Connect to the receiver unit with a single CAT5e/6 cable for transmission of all data signals
- ⑧ EDID: Auto: default 4K@60Hz  
Local: copy EDID from display of transmitter  
Remote: copy EDID from display of receiver
- ⑨ RS232 in: Connect to a PC or laptop with phoenix terminal for the transmission of RS232 commands

## 7.2 Receiver Front and Rear Panels

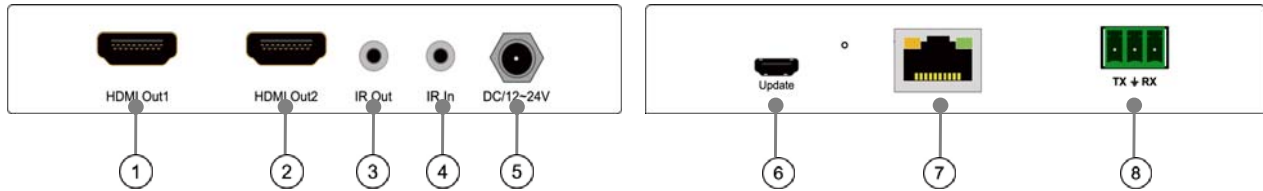

- ① HDMI Out1: Connect to a HDMI equipped TV/Monitor for display of the HDMI input source signal
- ② HDMI out2: Connect to a HDMI equipped TV/Monitor for display of the HDMI input source signal
- ③ IR Out: Connect to the supplied IR blaster cable for IR signal transmission. Place the IR blaster in direct line of sight of the equipment to be controlled
- ④ IR In: Connect to the supplied IR blaster cable for IR signal transmission. Place the IR blaster in direct line-of-sight of the equipment to be controlled.
- ⑤ DC/12-24V: Plug the 24V DC power supply into the unit and connect the adaptor to an AC outlet
- ⑥ Update: USB port to update the firmware
- ⑦ CAT5e/6 In : Connect to the transmitter unit with a single CAT5e/6 cable for transmission of all data signals
- ⑧ RS232 Out: Connect to the device that is to be controlled via phoenix terminal by RS-232 commands

## 8. CONNECTION DIAGRAM

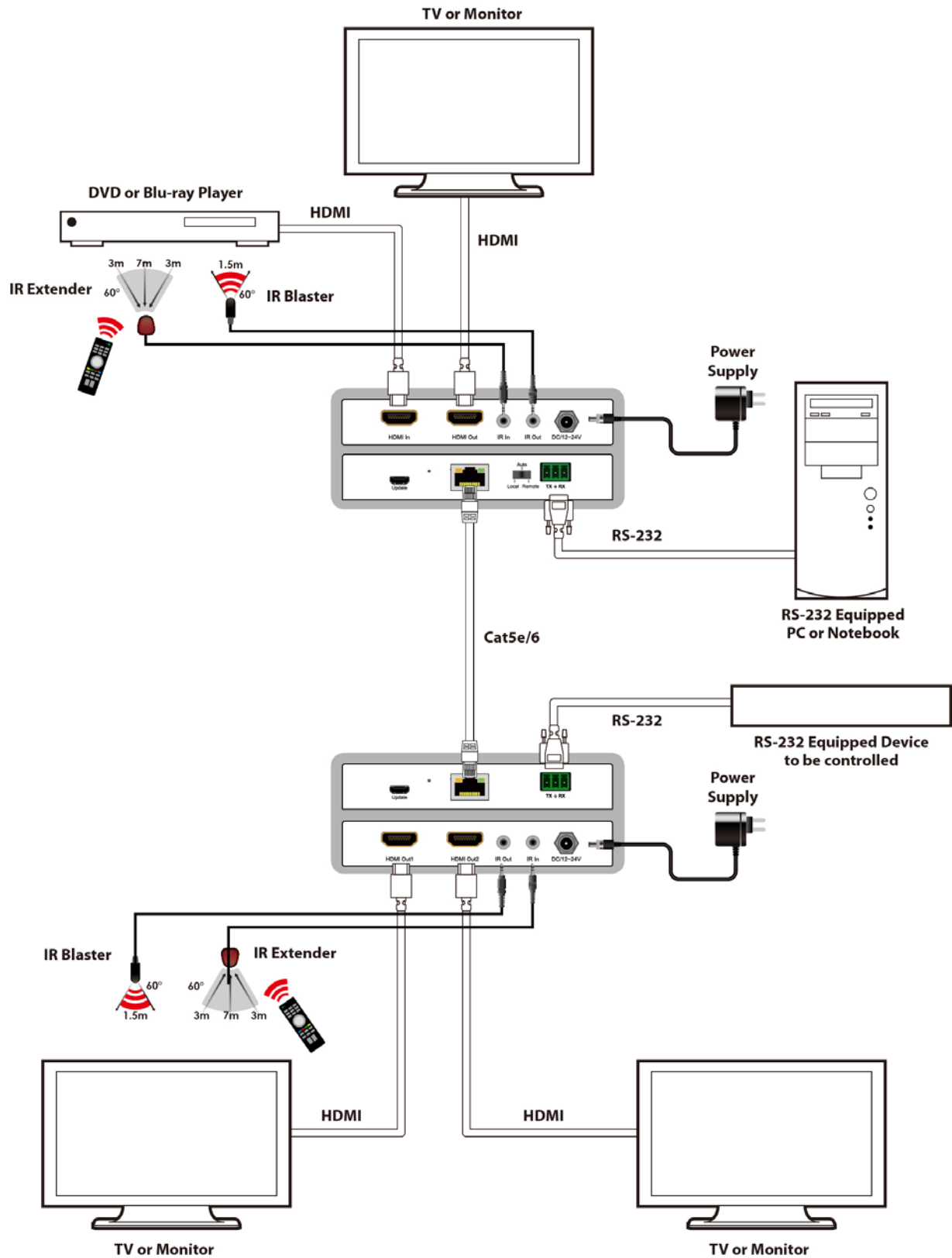



## 9.MAINTENANCE

Clean this unit with a soft, dry cloth. Never use alcohol, paint thinner or benzene to clean this unit.

## 10.PRODUCT SERVICE

### (1) Damage requiring service:

The unit should be serviced by qualified service personnel if:

- (a) The DC power supply cord or AC adaptor has been damaged;
- (b) Objects or liquids have gotten into the unit;
- (c) The unit has been exposed to rain;
- (d) The unit does not operate normally or exhibits a marked change in performance;  
The unit has been dropped or the cabinet damaged.

**(2) Servicing Personnel:** Do not attempt to service the unit beyond that described in these operating instructions. Refer all other servicing to authorized servicing personnel.

**(3) Replacement parts:** When parts need replacing ensure the servicer uses parts specified by the manufacturer or parts that have the same characteristics as the original parts. Unauthorized substitutes may result in fire, electric shock, or other Hazards.

**(4) Safety check:** After repairs or service, ask the servicer to perform safety checks to confirm that the unit is in proper working condition.

## 11.WARRANTY

If your product does not work properly because of a defect in materials or workmanship, our Company (referred to as "the warrantor" ) will, for the length of the period indicated as below, **(Parts(2)Year, Labor(90) Days)** which starts with the date of original purchase ("Limited Warranty period"), at its option either(a) repair your product with new or refurbished parts, or (b) replace it with a new or a refurbished product. The decision to repair or replace will be made by the warrantor. During the "Labor" Limited Warranty period there will be no charge for labor. During the "Parts" warranty period, there will be no charge for parts. You must mail-in your product during the warranty period. This Limited Warranty is extended only to the original purchaser and only covers product purchased as new. A purchase receipt or other proof of original purchase date is required for Limited Warranty service.