

4x4 Seamless HDMI matrix 4K@60hz 2.0 version with 2x2 video wall

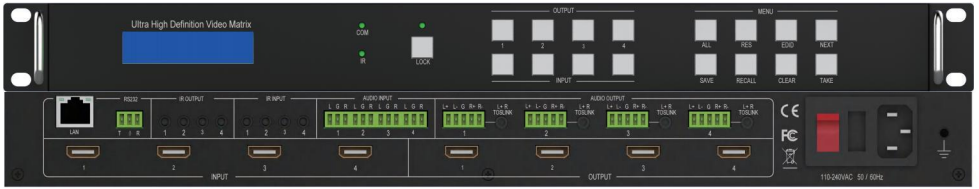

Dear Customer

Thank you for purchasing this product. For optimum performance and safety, please read these instructions carefully before connecting, operating or adjusting this product. Please keep this manual for future reference.

Table of Contents

Introduction.....	1
Features.....	1
Package Contents.....	1
Specifications.....	2
Operation Controls and Functions.....	4
RS232/LAN Control.....	5
RS232 Connector.....	5
Ethernet Control and Connection.....	5
PC Tool User Guide.....	5
Account's Authentication.....	5
Connect with PC Tool.....	6
Matrix Switch Page.....	7
Advanced Switch Page.....	8
Signal Setting Page.....	9
FineTune Page.....	10
Video Wall Page.....	11
CEC control Page.....	11
Control via Web.....	13
Appendix A: Query IP Info via UART.....	14
Appendix B: Query IP Info via UART.....	15
Appendix C: Set IP Info via UART.....	16
Appendix D: Set IP Info via Network.....	17
Appendix E: Set IP Address on Windows 7 or XP.....	18
Appendix F: Direct Connect via Ethernet Cable.....	20
Appendix G: Connect via Network Router /Switch.....	21
Appendix H: Troubleshoot with Network Control.....	22
Connection Diagram.....	23

Introduction

CA44M-VS is a 4K@60hz 4:4:4 HDMI 2.0 version 4x4 matrix,it support seamless function, switching no delay time.Support CEC and IR function and support front panel keys control, IR and IP control(PC tool, Web GUI).It offers solutions for home, office, digital entertainment center, control center, conference room, school and corporate training environments.

Features

- 1.HDMI 2.0 version matrix 4x4 with 2x2 video wall.
- 2.Support 4K@6hz 4:4:4 18Gbps.
- 3.Seamless switching,no delay time.
- 4.Support CEC audio extraction and IR.
- 5.Smart EDID management.
- 6.Support control via front keys,RS232,TCP/IP control (PCtool and WEB GUI).
- 7.Power max 60W, weight 5KG, dimensions :430mm (W)×220mm (D)×44mm (H)

Package Contents

- 1 x 4x4 seamless UHD Matrix
- 1 x AC Power Cord
- 1 x Matrix IR Remote
- 4 x IR Receiver cable (1.5 meters)
- 4 x IR Blaster cable (1.5 meters)
- 1 x 3-pin Phoenix Connector

Specifications

Technical	
HDMI Compliance	HDMI 2.0
HDCP Compliance	HDCP 2.2
Video Bandwidth	18Gbps
Video Resolution	Up to 4K60 4:4:4
Color Space	RGB, YCbCr 4:4:4/4:2:2
HDMI Amplitude	T.M.D.S +/- 0.4Vpp
Differential Impedance	100±15ohm
ESD Protection	Human-body Model: ±8kV (Air-gap discharge) , ±4kV (Contact discharge)
RS232/Ethernet Control	
Baud rate and Protocol	Baud rate: 9600, data bit: 8 Stop bit: 1, no parity checking
Ethernet	IE10.0+,HTML5
Mechanical	
Housing	Metal Enclosure
Color	Black
Dimensions	430mm (W)×300mm (D)×44mm (H)
Weight	5Kg
Power Supply	AC 110 - 240V
Power Consumption	60W (Max)
Operating Temperature	0°C ~ 40°C / 32°F ~ 104°F
Storage Temperature	-20°C ~ 70°C / -4°F ~ 158°F
Relative Humidity	10%~50% RH (non-condensing)

Operation Controls and Functions

Front Panel



Output/Input buttons:

Press buttons OUTPUT n + INPUT m+ TAKE by sequence, switch the matrix input m to output n.

Press button LOCK more than 2 seconds and less than 6 seconds, to lock or unlock front buttons. When locked, the Lock LED is on;

Press button LOCK more than 6 seconds, enter into the input output lock menu, then press INPUT Or OUTPUT button to toggle the input or output lock status, then press TAKE to confirm. Press CLEAR to exit.

Press buttons ALL + INPUT m + TAKE by sequence, to switch input m to all the outputs.

Press buttons SAVE + OUTPUT n to save current routing/video wall scene as scene n. Up to 8 scenes can be saved.

Press buttons RECALL + OUTPUT n to recall routing scene n as the current routing.

Press buttons RES + OUTPUT n + NEXT + TAKE, to change the output resolution of OUTPUT n.

Resolution options:

3840x2160@60, 3840x2160@50, 3840x2160@30, 3840x2160@25,

1920x1200@60, 1920x1080@60, 1920x1080@50, 1600x1200@60,

1400x1050@60, 1366x768@60, 1360x768@60, 1280x1024@60,

1280x768@60, 1280x720@60, 1280x720@50, 1024x768@60

Press buttons EDID + INPUT m + NEXT + TAKE, change the EDID mode of port INPUT m EDID options:

Manual, 3840x2160@60, 3840x2160@30, 1920x1200@60,

1920x1080@60, 1280x1024@60, 1280x720@60, 1024x768@60

Manual EDID is loaded by PC Tool

Rear Panel



LAN(10M/100M), RS232 are for PC control.

Analog Audio IN/OUT ports bind to corresponding HDMI ports.

For example:

If HDMI 1 audio source is selected with External LR, then analog AUDIO IN LR1 (with phoenix connector) will be selected to replace the embedded audio of the HDMI input 1 data stream. If HDMI 1 audio source is selected with AUTO by PC TOOL or command, then the original embedded audio of input HDMI 1 will be used as its audio data stream. If the input is DVI signal, no matter how it is set up, system will get external analog audio input. Analog AUDIO OUT n will always output the same audio content with HDMI OUTPUT n.

IR IN and IR OUT

IR IN/OUT routing follows the video matrix routing, no need to separately control IR matrix.

IR extender connectors (not as accessories)

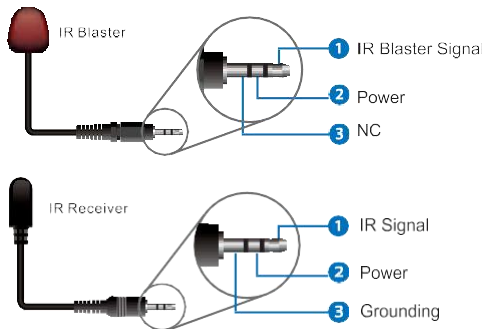

Audio Input

4 3-pin Phoenix connectors to input external analog LR audio, user can select this audio to replace the corresponding embedded HDMI audio.

Audio Output

4 5-pin Phoenix connectors to output balanced LR audio, and 4 mini Toslink jackets to output analog LR audio and digital Spdif audio.

The 4 sets of Audio output (LR and Toslink) channels can be independent of video and switched by PC Tool or commands.

1. RS232/LAN Control

1.1 RS232 Connector

RS232 control, baud rate 9600, 3-pin Phoenix connector.



TX GND RX

TX pin, Matrix--->PC

RX pin, Matrix<---PC

1.2 Ethernet Control and Connection

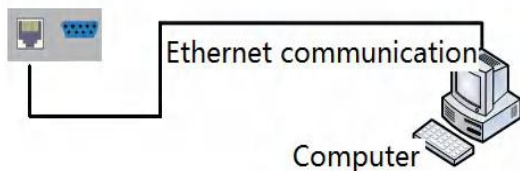

Note: Factory default network setting:

IP Type	Static IP
Static IP	192 . 168 . 0 . 247
Subnet Mask	255 . 255 . 255 . 0
Gateway	192 . 168 . 0 . 1

2. PC Tool User Guide

2.1 Account's Authentication

Before running the PC tool, the password is needed for authentication.

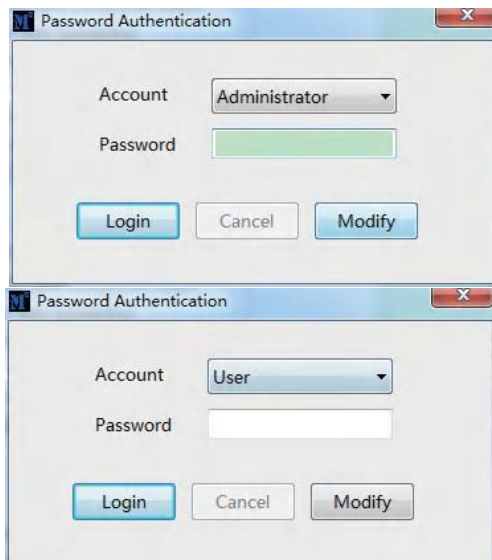

Default password of Administrator: 111111
 Default password of User: 000000

NOTE: In case of password lost, there's a super password to login and modify password:
 Smartsecuri@2010

You can modify the password by following steps:

Step 1. Click the drop-down list to select account: Administrator or User.

Step 2. Input the current password, then click the “modify” button to authenticate.

Step 3. Input the new password twice, then click the “modify” button.

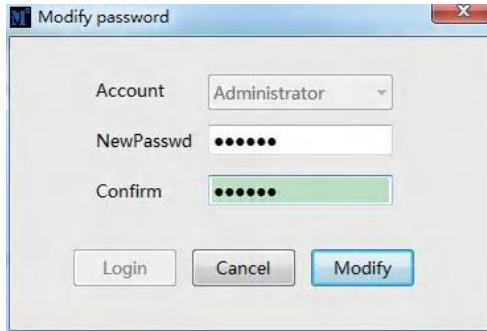

3.1 Connect with PC Tool

1. The default PC tool's UI style is as below.

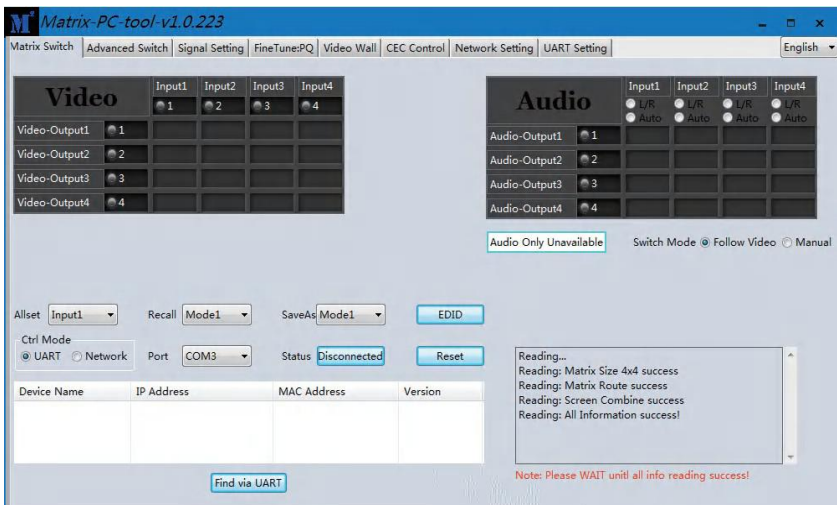

2. You can select **UART** (with RS232 cable) or **Network** to connect, baud rate is 9600 bps.

3. **Network control** (with cat5/6 cable, default IP address: 192.168.0.247) includes the following operations:
 - a) Query IP information via UART, please refer to **Appendix A**.
Or query IP information via Network, please refer to **Appendix B**.
 - b) Set IP information via UART, please refer to **Appendix C**.
Or set IP information via Network, please refer to **Appendix D**.
 - c) Set IP address on Windows 7/XP, please refer to **Appendix E**.
 - d) User can directly connect via Ethernet cable (please refer to **Appendix F**). Or connect via network router/switch (please refer to **Appendix G**).
 - e) Click Connected button to setup link and connect
4. When the product is connected with PC Tool, there may be connection failure, please refer to **Appendix H: Troubleshoot with Network Control**.

4.1 Matrix Switch Page

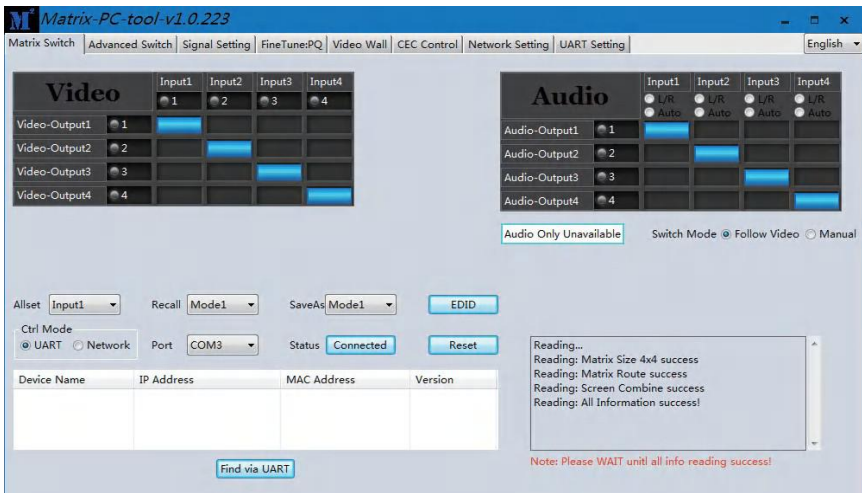

1. There is a shortcut button to switch one input port to all output ports, that is Allset, For example, switch input 1 to all outputs, user can select

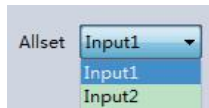

2. Recall mode: Recall a input/output routing scene which already be saved before. The device supports maximum 8 scenes.
3. Save mode: Save the current input/output routing in one index. Maximum 8 modes supported.
Note: Save/Recall button here works the same with front panel save/recall control and also the same with Save/Load function on video wall page.
4. System reset: The PC tool supports reset system to recover to factory configuration.

5. Audio Switch mode: Follow Video mode or Manual mode

When selecting Manual mode, user can separately switch L/R(Phoenix interface) and Toslink output.

User also can select to use HDMI embedded or corresponding external LR audio.

6. EDID Control: Click the “EDID” button on Matrix Switch page, there will be a pop-up EDID control window.

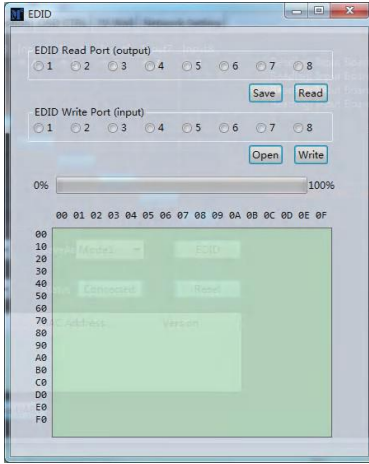

- Read EDID: Select the output port, then click the “Read” button to read EDID.
- Write EDID: First read a EDID from output port, then open a EDID file that saved before, then select the input port, and click the “Write” button to write EDID.
- Save EDID: After reading EDID successfully, Click “Save” button to save.
- This EDID for one input port acts as the Manual EDID, which can be selected or deselected by the front panel.

5.1 Advanced Switch Page

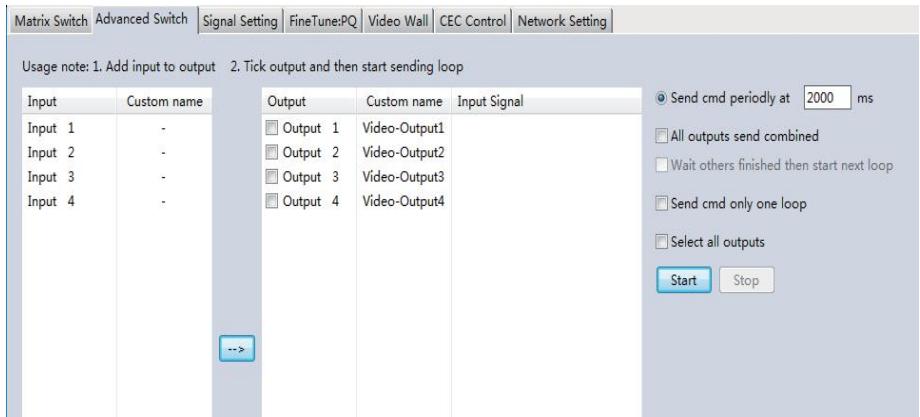

The Advanced Switch page will repeatedly send a batch of matrix selection commands at the interval specified in the value box after **Send cmd periodically** at text.

- Select one or more outputs.
- Select one input.
- Use the arrow button “-->” to assign that input to the selected output or outputs.
- After completing all required selections, click the “Start” button to run the commands.

The available options are:

All outputs send combined – Combine all outputs that have the same input number as a single command.

Wait others finished the start next loop – Wait for all commands in the previous pass to complete before sending the next batch of commands.

Send cmd only one loop – Only send a single batch of commands. **Select**

all outputs – Select all outputs when the option is checked. **Start** – Begin the command cycles.

Stop – Stop the command cycles.

6.1 Signal Setting Page

Label	Input Type	Input Format	Audio Select	Output Type	Output Format	
1	UHD-HDMI	No Signal	Auto	UHD-HDMI	4K2Kp30	Read
2	UHD-HDMI	No Signal	Auto	UHD-HDMI	4K2Kp30	Read
3	UHD-HDMI	No Signal	Auto	UHD-HDMI	4K2Kp30	Read
4	UHD-HDMI	No Signal	Auto	UHD-HDMI	4K2Kp30	Read

1. Audio Select

There are two options for input Audio Select.

a) Auto: If the input source is HDMI signal, system will get the embedded audio; if the input source is DVI signal, the system will get the corresponding analog audio.

b) External: System will get the corresponding analog audio.

2. Output Type

There are four options for input Output Type: UHD-HDMI (HDCP OFF), UHD-DVI, UHD-HDCP-1.4, UHD-HDCP-2.2.

3. Output Format

User can set the output resolution: 3840x2160@60, 3840x2160@50, 3840x2160@30, 3840x2160@25, 1920x1200@60, 1920x1080@60, 1920x1080@50, 1600x1200@60, 1400x1050@60, 1366x768@60, 1360x768@60, 1280x1024@60, 1280x768@60, 1280x720@60, 1280x720@50, 1024x768@60.

7.1 Fine Tune Page

You can read and set the Brightness/Contrast/Saturation/Sharpness of each output.

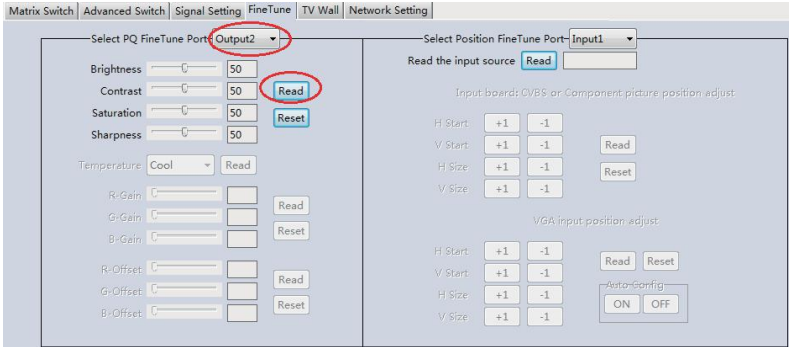

Note: Do not change the default settings without special conditions;

If there is a problem after changing, click “Reset” to return to the factory settings.

8.1 Video Wall Page

Set the video wall display by setting the rows, columns and quantity of layout.

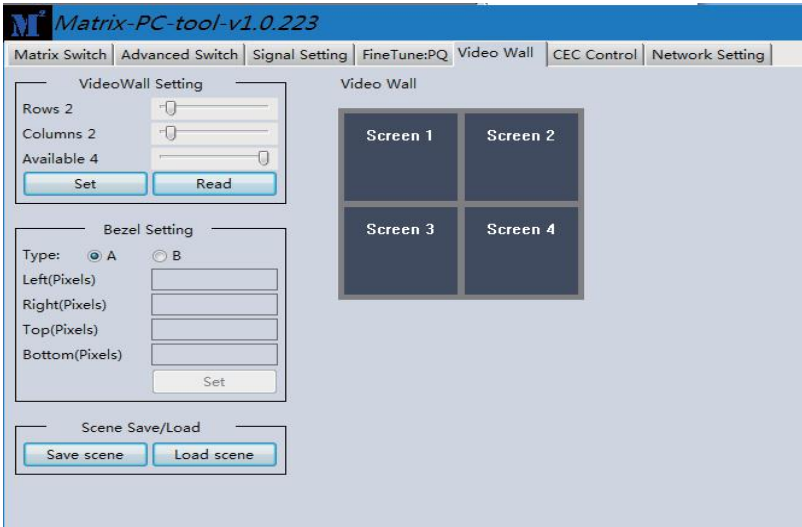

Build a Wall

Select one screen, right click, there will be a sub menu as the following picture shows:

Input Select: Select the input port, for the screen to display (Input 1 ~ Input 8).

Output Select: Set the output port that connects to the display according to the video wall connect status.

Output Format: Set the output resolution.

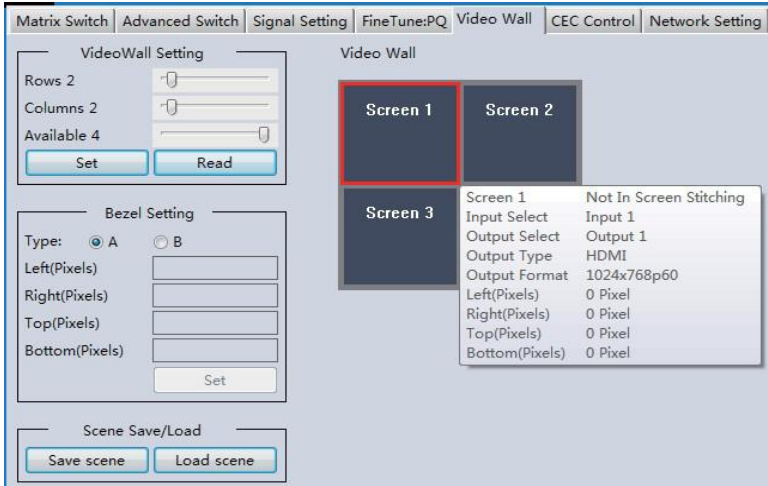

Click to select one screen, then drag, select the screens to be spliced, right click, and select "Screen Stitching" to splice.

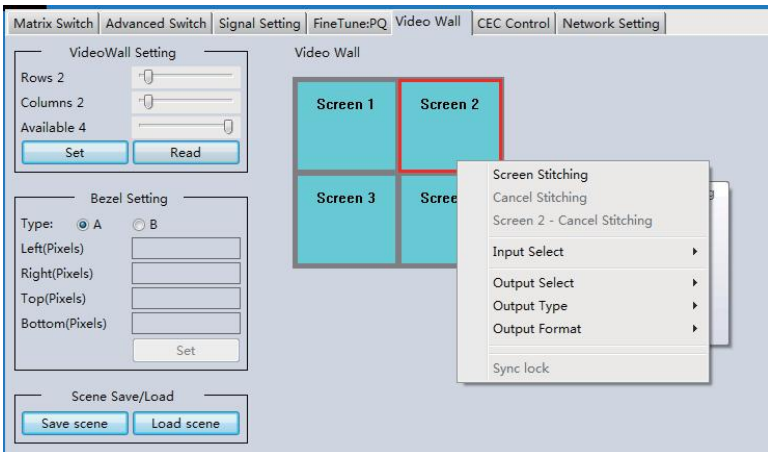

If you want to cancel one TV WALL, first select the wall which is splicing, right click, then select "Cancel Stitching".

Bezel adjust

There are two options to set bezel.

Type A with pixels setting, maximum number is 255, see below:

Type B with millimeter setting, see below:

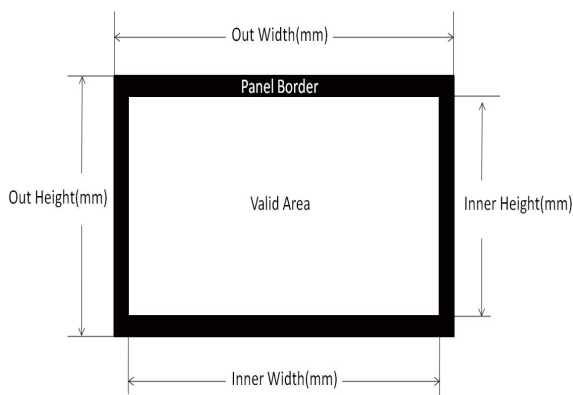

One more TV Wall

The product supports multiple TV wall at the same time, for example two 2x1 walls. Each wall has its own bezel setting. Click one wall and then set bezel one by one.

PIP with TV Wall

The following is one 2x2 wall, for example. If you want screen 3 to separately display another video source, you can right click Screen 3 and select “Screen 3 - Cancel Stitching”, then select the same or another video source for screen 3 to display. This separate screen is a full display screen.

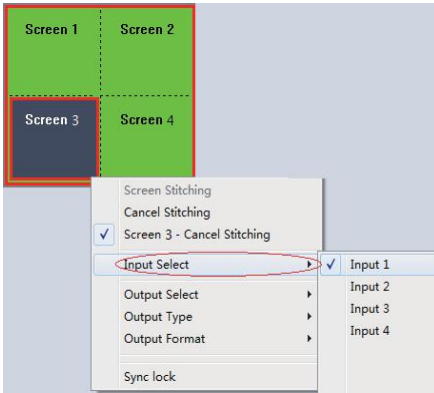

Multi-view in video wall

Save Scene/ Load Scene

On the Video Wall page, you can save or load one splicing wall scene , including input/output routing and wall layout.

CEC Control Page

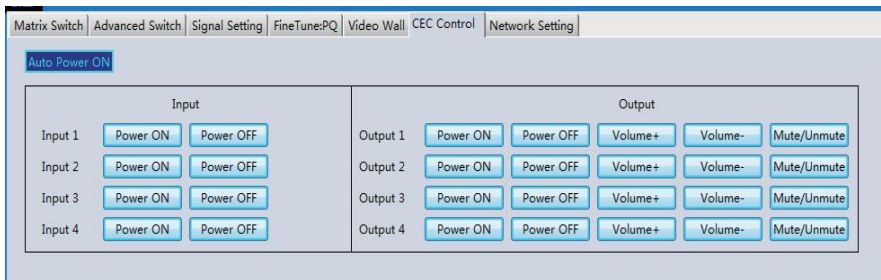

If **Auto Power On** is enabled, every time when the product is turned on, it will turn on all the sources and displays which are connected to it.

The product supports CEC function, including Power on/off, Volume+/-, Mute/Unmute.

9. Control via Web

The product supports Web control.

Enter the Web GUI by the following steps:

Step 1. Directly input the IP address in the web browser, then press 'Enter' key.

Step 2. Input the username: admin.

Step 3. Input the password: admin.

Step 4. Login and then you can control the matrix switch via the web.

Note: On web control, you can only control basic operation.

10. Appendix A: Query IP Info via UART

Method 1: After connecting to the device via UART, click the “Find via UART” button at “Matrix Switch” page to read the IP information.

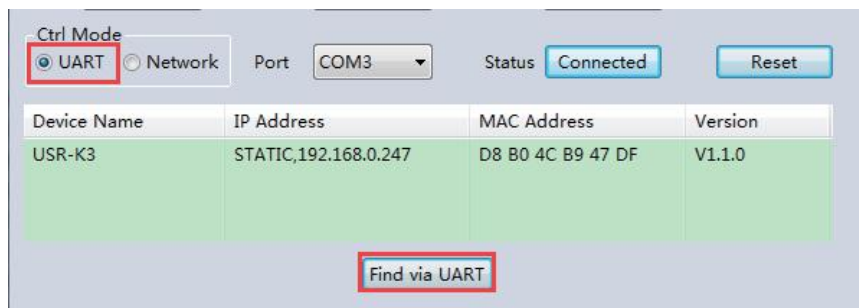

Method 2: After connecting to the device via UART, click the “Find via UART” button at “Network Setting” page to read the IP information.

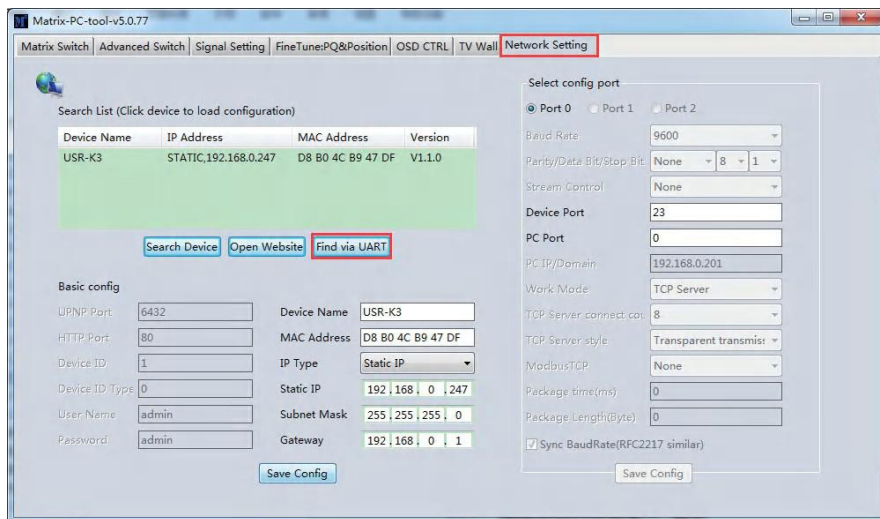

11. Appendix B: Query IP Info via UART

After connecting to the device via network, we can query information through two methods. **Method 1:** Switch to “Matrix Swtch” page, then click “Search Device” button to query IP information.

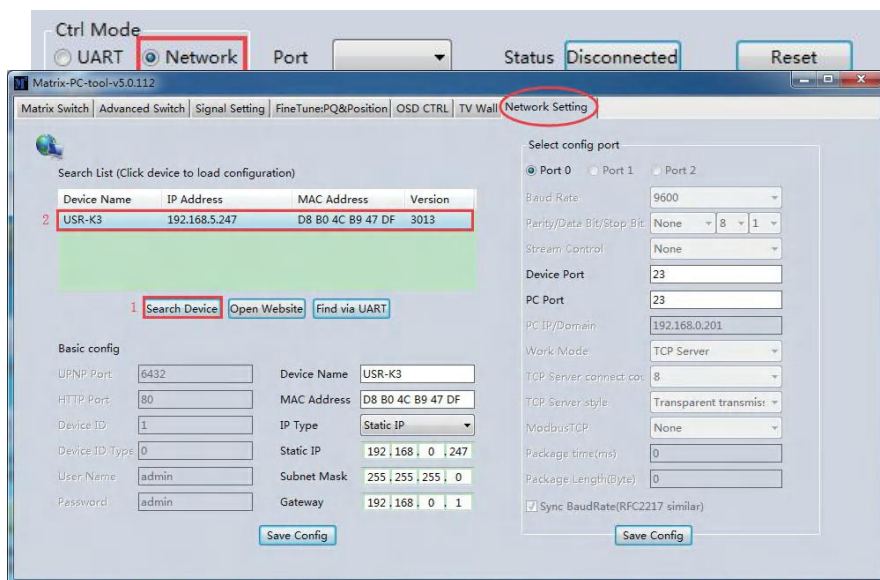

Method 2: After switching to “Network Setting” page, click “Search Device” button to search devices, then click one device in the result list to load its IP information.

12. Appendix C: Set IP Info via UART

Set IP information via UART by doing the operation below:

Step 1. After connecting to the device via UART, switch to “Network Setting” page.

Step 2. Click “Find via UART” button to read IP information.

Step 3. Modify IP address type to Static IP or Auto IP(DHCP). If IP address type is modified to Static IP, then input IP address, subnet mask and gateway information.

Step 4. Click “Save Config” button to save.

Step 5. Click “Find via UART” button again to read IP information to make sure the modification is completed successfully.

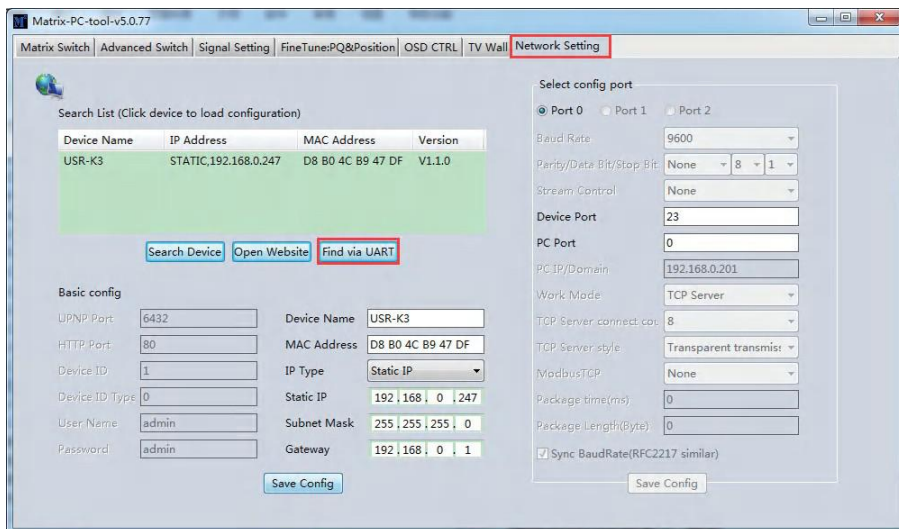

Note: Configuration via UART only support modify IP address or IP address type. If you want to modify other configuration, please configure it via Network.

13. Appendix D: Set IP Info via Network

Set IP information via network by doing the operation below:

Step 1. After connecting to the device via network, switch to “Network Setting” page.

Step 2. Click “Search Device” button to search devices.

Step 3. Click the device you want to configure in the result list (When you click it, the software will read the network configuration of the device automatically).

Step 4. Modify the IP address, the IP address type or other configuration.

Step 4. Click “Save Config” button to save.

Step 5. When the software shows a message of “Success”, click “Search Device” button to load configuration again to make sure your modification is saved successfully.

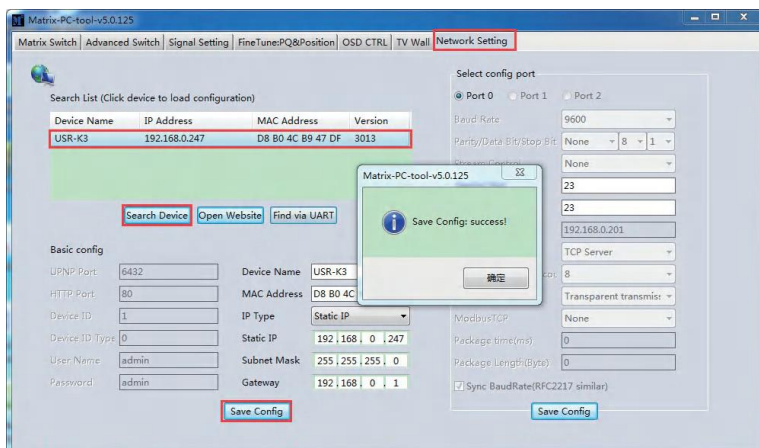
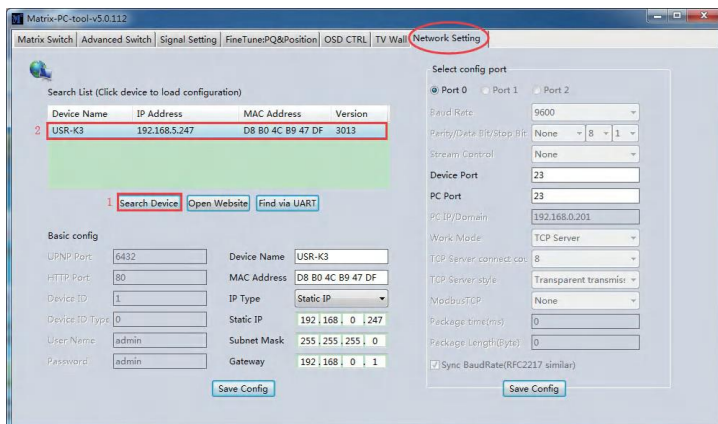

Note: When selecting the device, it will display the matrix’s network board information. You can edit the device’s name, in order to better identify matrix. You can set dynamic IP/ static IP, subnet mask, gateway and other network information. At the same time, you can also set the device port. Serial port baud rate is 9600 (You cannot change the baud rate, otherwise it will lead to network control failure).

14. Appendix E: Set IP Address on Windows 7 or XP

1. Windows 7: Open “Network and Sharing Center” on PC.

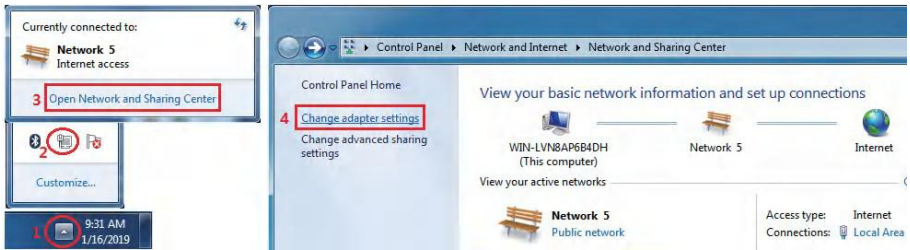

Modify the static IP address of PC (e.g. 192.168.0.1):

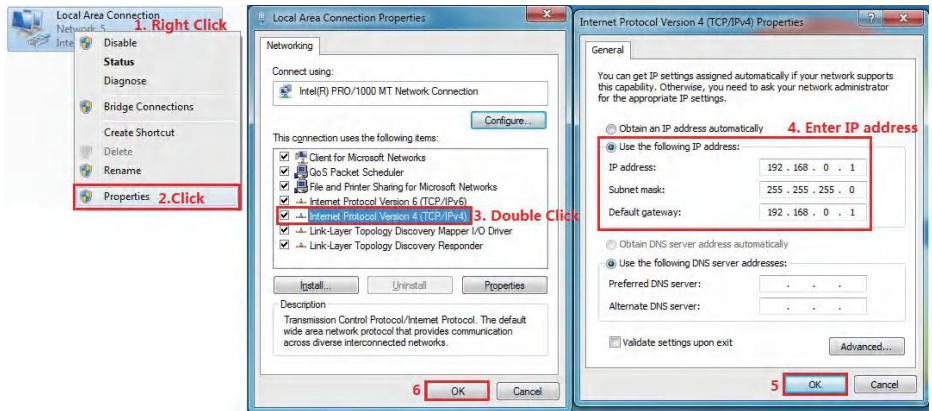

2. Windows XP: Open “Network Connections” on PC.

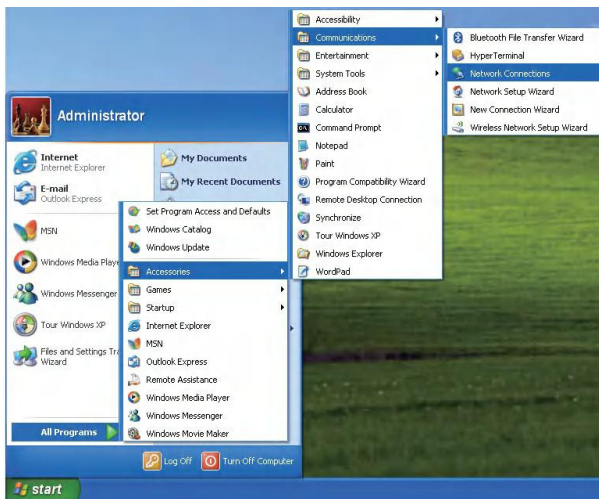

Modify the IP address of “Local Area Connection” (e.g. 192.168.0.1):

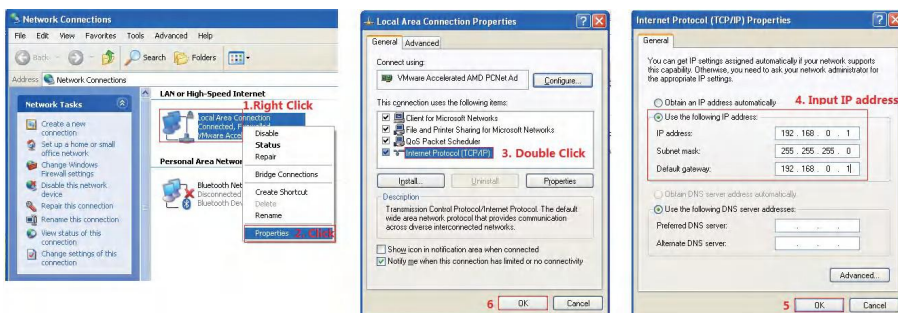

15. Appendix F: Direct Connect via Ethernet Cable

Operation steps are as follows:

Step 1. Connect the PC and device directly via an Ethernet cable.

Step 2. Manually set up the IP address of the PC, which should be in the same network segment with the device (The default IP address of the device is 192.168.0.247, and the default network mask of the device is 255.255.255.0).

Step 3. Run the PC control software (**If the IP address of the PC is changed after running the software, you should close it and run it again**).

Step 4. Click to switch “Ctrl Mode” to “Network”.

Step 5. Click the ‘Search Device’ button.

Step 6. Click the device you want to control in the result list (When you click it, the software will read the network configuration of the device automatically).

Step 7. Click the “Disconnected” button (which is right to “Status”) to connect the device. **Step 8.** After connected successfully, the button right to “Status” will turn to “Connected” (If you click it now, it will disconnect from the device).



Note: The default IP address of the device is 192.168.0.247, and the default subnet mask is 255.255.255.0.

16. Appendix G: Connect via Network Router /Switch

Operation steps are as follows:

Step 1. Connect the PC and device to a same network router.

Step 2. Set up the IP address of the PC. Either manual (Static) mode or automatic (DHCP) mode.

Step 3. Just make sure the IP address of the PC and the device are in a same network segment (When the IP type is obtained automatically, the network router that PC and device connected to should support HDCP function)

Step 4. Run the PC control software (**If the IP address of the PC is changed after running the software, you should close it and run it again**).

Step 5. Click to switch “Ctrl Mode” to “Network”.

Step 5. Click the ‘Search Device’ button.

Step 6. Click the device you want to control in the result list (When you click it, the software will read the network configuration of the device automatically).

Step 7. Click the “Disconnected” button (which is right to “Status”) to connect the device. **Step 8.** After connected successfully, the button right to “Status” will turn to “Connected” (If you click it now, it will disconnect from the device).



Note: If the IP type of the device is Dynamic (DHCP) mode, the network router or switch must support HDCP function, otherwise the device will not be able to obtain a valid IP address, or the device will not be found. If the device can be found but not able to be connected successfully, please make sure the IP address of the PC and the device are in a same network segment. (e.g. if the subnet mask is 255.255.255.0, then 192.168.0.1 and 192.168.0.2 are in a same network segment.)

17. Appendix H: Troubleshoot with Network Control

1. Can't find any devices:

a) Cause A: The IP address type of the device is obtained automatically (DHCP), but the device is currently connected directly via an Ethernet cable or connected to a network device (router or switch) which does not support HDCP function.

Solution A: Set up the IP address type of the device to static mode, or connect the device to a network router which supports HDCP function.

b) Cause B: The device is not powered on.

Solution B: Please power on the device.

c) Cause C: The Ethernet cable is bad contact. Solution C:

Check the Ethernet cable's connection.

d) Cause D: The IP address type of the PC is obtained automatically (DHCP), but the PC is currently connected directly via an Ethernet cable or connected to a network device (router or switch) which does not support HDCP function.

Solution D: Set up the IP address type of the PC to static mode, or connect the PC to a network router which supports HDCP function.

e) Cause E: Unknown

Solution E: When connecting directly via Ethernet cable, please set up the IP address type both of the PC and the device to static mode, and the IP address of the both should be in a same network segment. Or when connecting via LAN, connect the PC and the device to a same network router which supports HDCP function.

2. The software shows a message of "device response timeout" after connecting to the device. Cause A: The IP address of the PC and the device are not in a same network segment. Solution A: Set up the IP addresses of the PC and the device, make sure they are in a same network segment.

3. The software shows a message of "TCP connection failed! Error Code: xxxx" after connecting to the device.

a) Cause A: The IP address of the PC and the device are not in a same network segment.



b) Solution A: Set up the IP address of the PC and the device, make sure they are in the same network segment.

c) Cause B: Firewall is enabled and PC tool is not admitted to passthrough.

d) Solution B: Disable firewall or add PC tool to white list so that it can be admitted to pass through.

Note: If the device's IP address type is Auto (DHCP), we can connect the device via UART firstly, then click the "Find Via UART" button to read the device's IP address. If the IP address of the device is 255.255.255.255 by this way, it means that the network device (the device connected to) does not support HDCP function.

Diagram :

- HDMI cable 
- Rj45 cable 
- Audio cable 